

Product ID
MTXS

MOTO-TOTE[®]

Motorcycle carriers

Spec Sheet

MOTO-TOTE *MTX Sport* motorcycle carrier

| | |
|---|--|
| Hitch type: | Class III or better 2 inch square |
| Track width: | 5" at front, 8.5" at rear |
| Wheel base: | Up to 65 inches |
| Tire Widths: | Front-Up to 5 inches, Rear-Up to 8.50 inches |
| Weight capacity: | 550 lbs.* |
| Carrier weight: | 58 lbs. |
| Material: | Powder coated steel |
| Ramp: | INCLUDED-Matching powder coated steel. Attaches to carrier for transport when not in use |
| Finish: | Baked polyester powder coat Black |
| Recommended for: | Sport and street bikes weighing up to 550 lbs.* |
| Suggested retail: | \$479.00 |
| MOTO-TOTE[®] Standard features: | <ul style="list-style-type: none"> • Easy one time assembly with only one-size wrench • Reversible assembly to position the bike either direction • Exclusive Zero-Wobble (tm) hitch attachment eliminates play • Heavy duty polyester powder coat finish • Quick stowing of loading ramp • Easy Storage – Takes about same space as a bicycle |
| MTX Sport New features: | <ul style="list-style-type: none"> • Adjustable wheel base • Adjustable for distance from vehicle • Wheel stop holds bike upright while you tie it down • Compatible with the MTX Platform System |



SIDE



Wide track for rear tire widths up to 8.50 inches

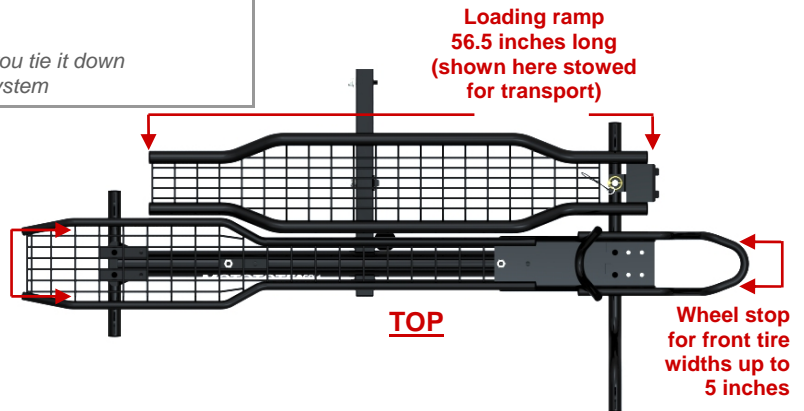

TOP

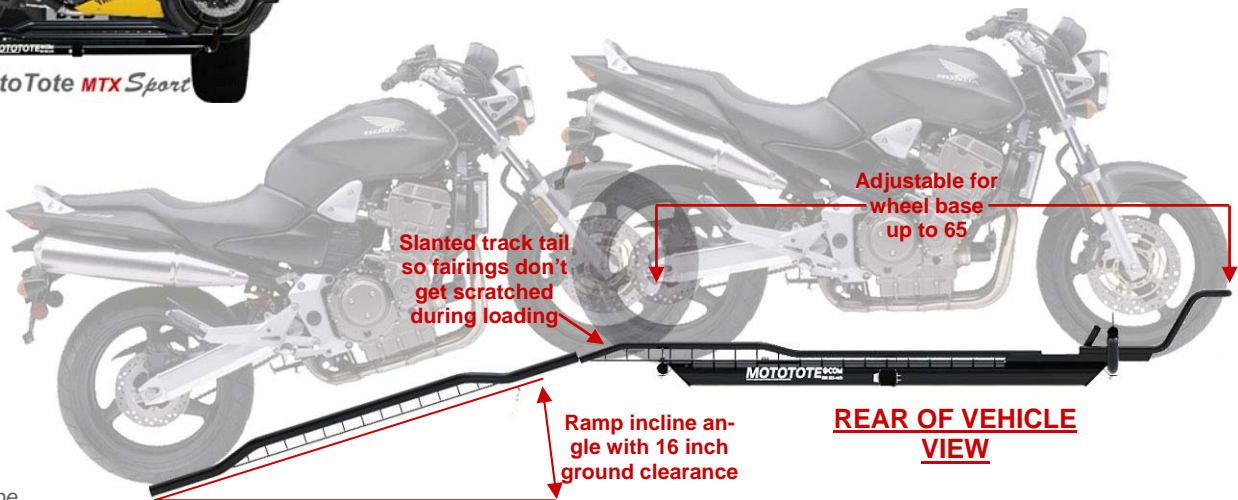

REAR OF VEHICLE VIEW

*Your vehicle and hitch must be rated to support the combined weight of the bike and the carrier

MOTO-TOTE is a registered trademark of D&D Design, Inc.
Patent #D393241

For more information, call (888) 333-4621 or visit MOTOTOTE.com

by **D&D Design, Inc.**